

A →

A →

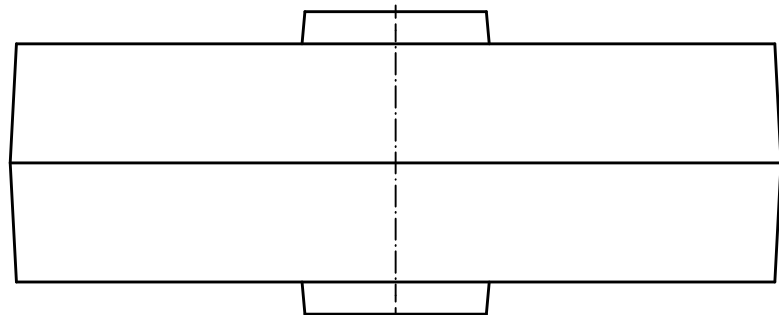

A-A (1:1)

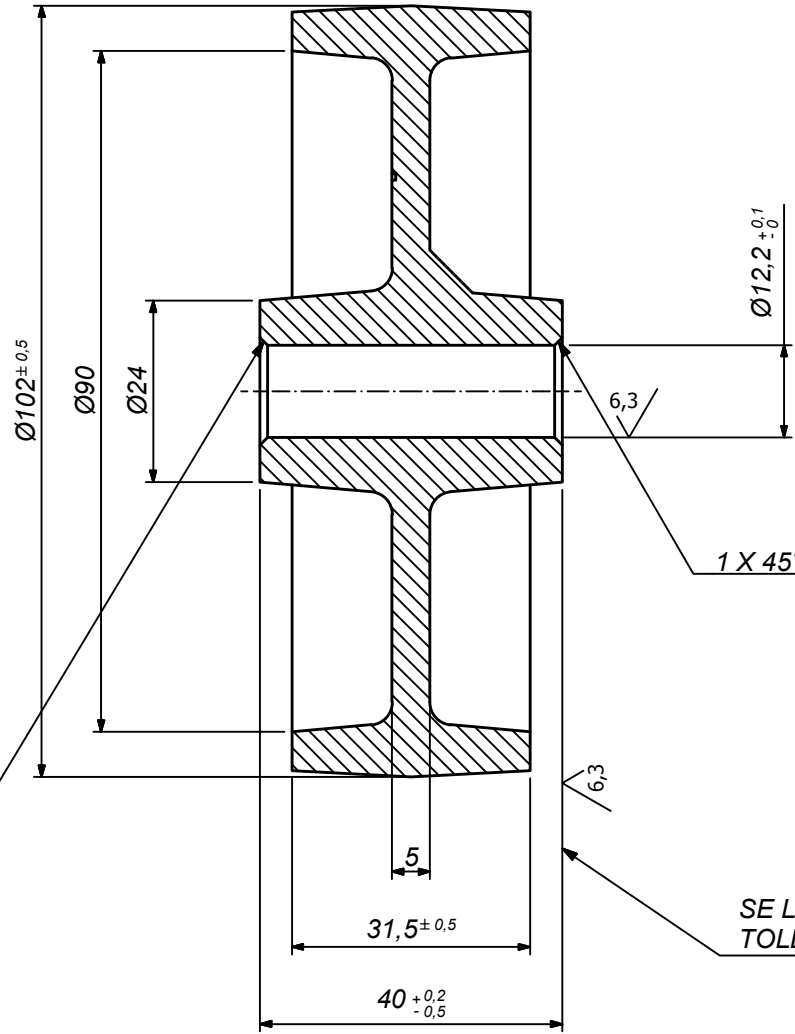

1 X 45° Smusso

1 X 45° Smusso

SE LA FUSIONE E' GIA' IN TOLLERANZA NON LAVORARE

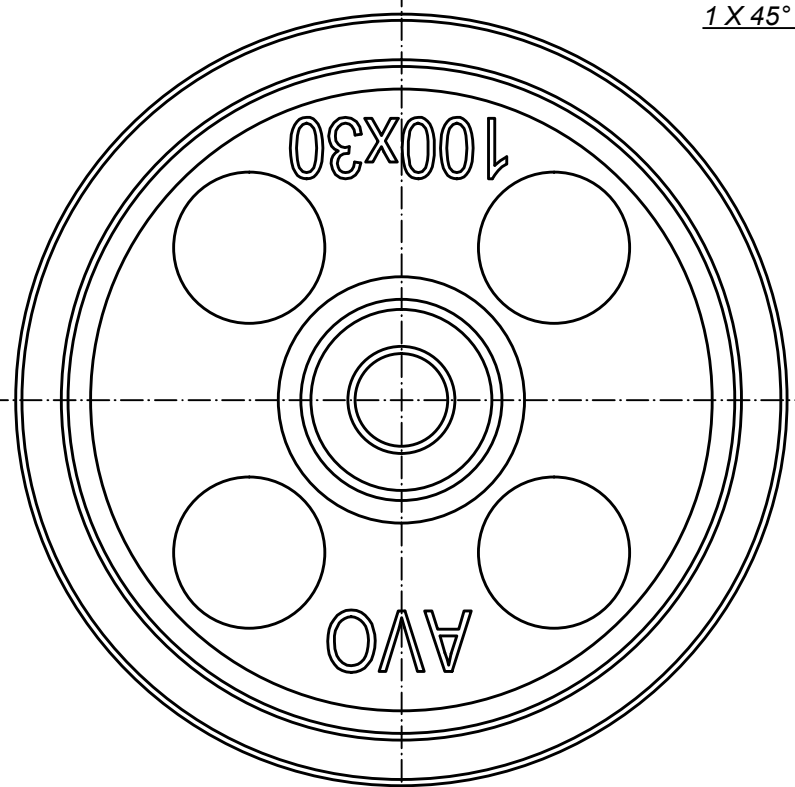
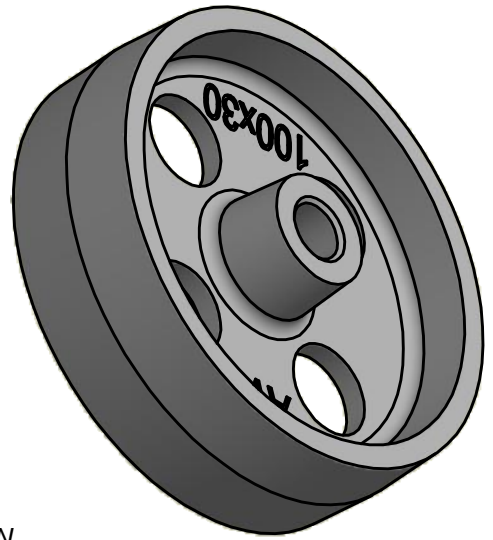
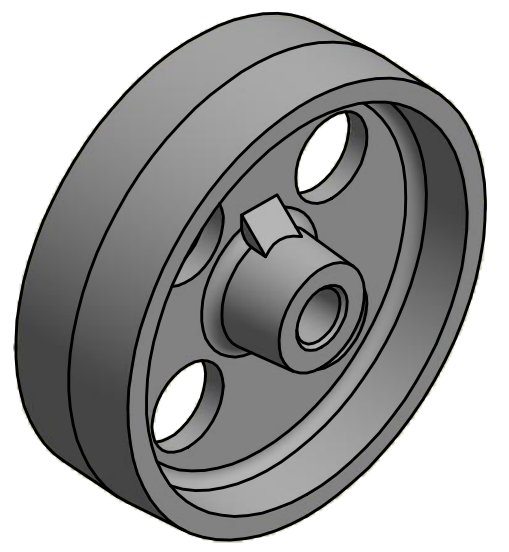

DUREZZA: da 170HB a 190HB

 ALDO VALSECCHI SpA via XX settembre, 107 28883 Gravelona Toce (VB) www.avo.it E' vietata ogni riproduzione anche parziale e la concessione a terzi se non preventivamente autorizzata	Tolleranze Generali: rif. UNI EN 22768/1 - C		Rugosità Ra[μm] e note: 6,3 () - NO BAVE - NO SPIGOLI TAGLIANTI	
	Codice AVO: 04114001000FG		Sostituisce il dis. N°: Sostituito dal dis. N°:	
	Materiale: G15 EN-GJL-150 UNIEN1561_1998 UNI5007		Trattamenti:	
	Descrizione: ruota G15 ø100x30M40 ø12 tornitura		0,7 kg MASSA	
	Formato: A3	Emissione: BUAROTTI	Disegno N°: 09662	
	Scala: 1:1	Approvazione: <i>Ing. Monti</i>	Data: 17/10/2013	Revisione: